

HOSE REELS: 5085 SERIES

UP TO 50' Max hose capacity



Hose Reels



5085 Series HD Large Capacity Hose Reels

Full metal, heavy-duty, hose reel with hose capacity up to 50' x 1 1/2" hose.

Very tough construction

Large capacity reels, able to stand regular use and abuse in intensive duty applications

Fatigue resistant steel spring

For years of durable performance and even load when pulling and recoiling the hose

Spool mounted on two permanently lubricated and sealed ball bearings

To reduce torque load on spring for smooth retraction and longer life

Large latching area for easier operation

Dual Spring

Reels with 75' and 100' hose capacity include a dual spring for effective and consistent hose retraction

Hose reels offer four mounting positions

May be mounted in floor and tank positions

Hose reels are delivered in the floor mount position



MARKETS SERVED

- Fleets
- Lube trucks
- General manufacturing
- Mining and construction
- Railroad and mass transit

FLUIDS HANDLED

- Water
- Diesel
- Waste oil evacuation
- Low pressure bulk oil transfer

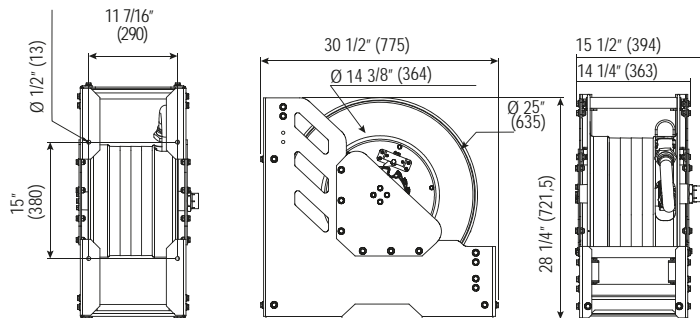

TECHNICAL SPECIFICATIONS

Operating Temperature Range	
Air / Water / Antifreeze	-22°F / 194°F - (-30°C / 90°C)
Oil	-22°F / 194°F - (-30°C / 90°C)
Wetted Parts	
Air / Water / Antifreeze	Steel , electroless nickel plated steel, Nitrile rubber, electroless nickel plated aluminum
Oil	Steel , electroless nickel plated steel, Nitrile rubber
Weight <i>without hose</i>	92.5 lb (43 Kg)
Manual	850 833

Hose Reels

ORDER INFORMATION

Part No.	Hose Length	Hose I.D.	Outlet thread	Max. Working Pressure	Net weight	Reel only with swivel Part No.
BARE REEL water, diesel & evacuation - steel shaft and swivel - inlet 1 1/2" NPT(F)						
508 891	Capacity up to 50' x 1 1/2"		1 1/2" NPT(M)	580 psi	150 lb	508 891

Recommended Accessories for use with 5085 series reels



528 083

Hose stop and U-bolt kit fits 1 1/2" hose