

# HOSE REELS: 508 SERIES

UP TO 100' Max hose capacity



Hose Reels



## 508 Series HD Large Capacity Hose Reels

Full metal, heavy-duty, double pedestal hose reels, with hose capacity up to 100' x 1/2" hose.

### Very tough construction

Large capacity reels, able to stand regular use and abuse in intensive duty applications

### Fatigue resistant steel spring

For years of durable performance and even load when pulling and recoiling the hose

### Spool mounted on two permanently lubricated and sealed ball bearings

To reduce torque load on spring for smooth retraction and longer life

### Large latching area for easier operation

### Dual Spring

Reels with 75' and 100' hose capacity include a dual spring for effective and consistent hose retraction

### Hose reels offer four mounting positions

May be mounted in floor, ceiling and tank positions

### Hose reels are delivered in the ceiling mount position



MARKETS SERVED

- Fleets
- Lube trucks
- General manufacturing
- Mining and construction
- Railroad and mass transit

FLUIDS HANDLED

- Air
- Water
- Antifreeze solutions
- Synthetic and mineral oils
- Waste oil evacuation
- Diesel

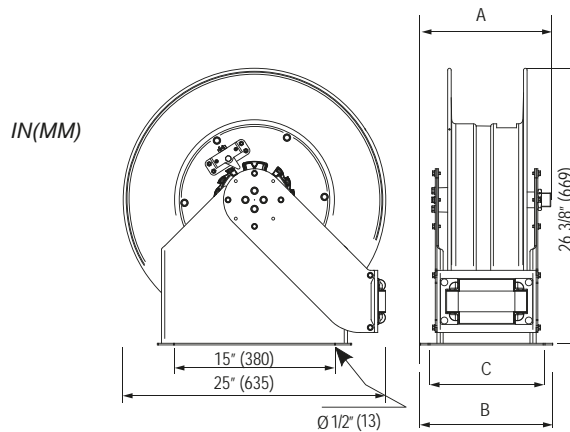

	508 002 Single Spring	508 046 Double Spring
A	12 3/8" (315)	13 3/4" (349)
B	11 3/8" (290)	12 5/16" (320)
C	12 5/16" (320)	13 15/16" (353)

## TECHNICAL SPECIFICATIONS

### Operating Temperature Range

Air / Water / Antifreeze / Oil	-22°F / 194°F - (-30°C / 90°C)
Wetted Parts	
Air / Water / Antifreeze / Oil	Steel, electroless nickel plated steel, Nitrile rubber
Weight <i>without hose</i>	92.5 lb (43 Kg)
Manual	850 837

Hose Reels

## ORDER INFORMATION

Part No.	Hose Length	Hose I.D.	Outlet thread	Max. Working Pressure	Net weight	Reel only with swivel Part No.	Springs
<b>LOW PRESSURE AIR/WATER</b> antifreeze and windshield wash solutions - brass shaft and acetal swivel - inlet 1" NPT(F)							
<b>508 125</b>	50'	1"	1" NPT(M)	300 psi	110.2 lb	508 002	Single
<b>508 152</b>	100'	1/2"	1/2" NPT(M)	300 psi	121.2 lb	508 046	Double
<b>LOW PRESSURE DIESEL</b> steel shaft and swivel - inlet 1" NPT(F)							
<b>508 425</b>	50'	1"	1" NPT(M)	300 psi	115.7 lb	508 002	Single
<b>MEDIUM PRESSURE OILS</b> steel shaft and swivel - inlet 1" NPT(F)							
<b>508 225*</b>	50'	1"	1" NPT(M)	1,250 psi	123.4 lb	508 002	Single
<b>508 244</b>	75'	3/4"	3/4" NPT(M)	1,250 psi	125.6 lb	508 046	Double
<b>508 252</b>	100'	1/2"	1/2" NPT(M)	2,000 psi	121.5 lb	508 046	Double

\*Hose reel 508 225 can also be used for waste oil evacuation

### Recommended Accessories for use with 508 series reels



<b>528 002</b>	Bi-conical hose stop and U-bolt kit fits 1/2" hose
<b>528 003</b>	Bi-conical hose stop and U-bolt kit fits 3/4" hose
<b>528 001</b>	Bi-conical hose stop and U-bolt kit fits 1" hose